

BauBuche Beech laminated veneer lumber

Fasteners and connections



Page	CONTENTS
2	5.1 Foreword
3	5.2 Mechanical fasteners
	5.2.1 Introduction
4	5.2.2 Nails
	5.2.3 Clamps
	5.2.4 Screws
11	5.2.5 Dowels/fit bolts/bolts
13	5.2.6 Rail splice connectors
14	5.2.7 Beam connectors
	5.2.8 Preformed steel parts
15	5.2.9 Installation on site / load-securing devices
	5.2.10 Fixture of large-size roof and wall elements
16	5.3 Carpentry connections
	5.3.1 Introduction
	5.3.2 Step joints
19	5.3.3 Dovetailed joints
20	5.4 Glued connections
	5.4.1 Introduction
21	5.4.2 Glued panel elements
	5.4.3 Screw press bonding
	5.4.4 Affixed reinforcements
	5.4.5 Glued-in steel rods

© Pollmeier Massivholz GmbH & Co.KG

Pferdsdorfer Weg 6
99831 Amt Creuzburg

BauBuche consulting service for
architects, civil engineers, builders and
timber construction companies
P +49 (0)36926 945 560
baubuche@pollmeier.com

Consulting service on sawn timber,
BauBuche, Pollmeier LVL and contact
person for the trade
P +49 (0) 36926 945 163
sales@pollmeier.com

5.1 Foreword

Fasteners and joints decisively contribute to the appearance of a timber construction. They should therefore be chosen at an early stage with due regard to the overall design and construction. Apart from the load bearing capacity and the visual impact, fire safety requirements might also need to be taken into account. This brochure has been compiled to assist you in choosing suitable fasteners and connections for your BauBuche constructions. Always consider the approvals of the fastener manufacturers. For details regarding dimensions, please refer to the »Eurocode 5 calculation and design tool for BauBuche laminated veneer lumber« available for download from www.pollmeier.com.

In general, load effects caused by changes of the moisture content of the wood have to be considered. BauBuche is delivered with a moisture content of 6% ($\pm 2\%$) and is highly susceptible to shrinking and swelling, at a rate of up to 0.45%/‰ perpendicular to the grain. Further to this, BauBuche must be protected from a direct exposure to rain at all times. For more information, see our **brochure 09** »Wood preservation & surface treatment«.

The dimensions in this brochure are guide values only and Pollmeier Massivholz GmbH & Co.KG does not assume any liability for the listed values.

5.2 Mechanical fasteners

5.2.1 Introduction

As a general rule, mechanical fasteners have to be dimensioned with reference to section 8 of EN 1995-1-1 in conjunction with the relevant national annex, using the equations for solid timber (hardwood).

All sides consisting primarily of end grain are considered face sides. In this document, the other sides are referred to as narrow sides («Fineline» look) and wide sides respectively. For fasteners covered by Eurocode 5, the values in the table below apply.

	Calculation according to ¹⁾	Wide side	Narrow side	Face side
Bearing stress				
Nails, screws (pre-drilled) ¹⁾	Equat. 8.16, DIN EN 1995-1-1	100 %	Option A: 100 %	Not permissible ¹⁾
Exemplary: BauBuche S Dowels and bolts	Equat. 8.32, equat. 8.31, DIN EN 1995-1-1 with $k_{90} = 0.9 + 0.015 \cdot d$	100 %	Load relative to board plane parallel: 70 % ²⁾ perpendicular: 80 %	Not permissible ¹⁾
Load bearing capacity of fastening unit				
Ring dowels, plate dowels	NCI NA 8.1, DIN EN 1995-1-1/NA	100 %	100 %	100 %
Withdrawal capacity				
Timber screws ($45^\circ \leq \alpha \leq 90^\circ$) ¹⁾	Equat. 8.38 ($k_d=1$), DIN EN 1995-1-1	100 %	100 %	100 %

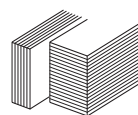
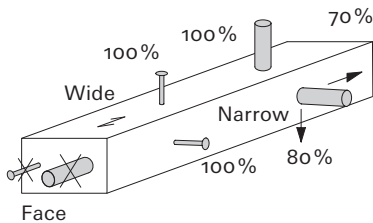

Option A applies to BauBuche S and
Beams BauBuche GL75
(longitudinal-ply laminated veneer lumber).

1) For fasteners subject to approval (AbZ or ETA), different values and rules may apply for use in BauBuche;

for instance, screws in face sides might be permissible, and the dimensioning rules might deviate from those in DIN EN 1995-1-1.

2) For Beams BauBuche GL75, the reduction factor for the embedding strength for pin-shaped fasteners with a diameter $d > 8$ mm used in narrow sides is 80% according to ETA-14/0354.

For calculations, use the following density for Board S and for Beams BauBuche GL75: 730 kg/m^3 . Combined loads must be calculated according to EN 1995-1-1 section 8.3.3.

For the production of timber connections with BauBuche, use only dowels and bolts (including fitting bolts), nails, timber screws, ring dowels or plate dowels and adhere to the instructions and specifications below. Also observe the application ranges in the above table. The minimum distances between fasteners that are exposed to shearing-off and withdrawal stress correspond to those for solid timber and plywood. If there is shearing-off stress at the narrow sides of a BauBuche Board S or Beam BauBuche GL75, the nails must have a minimum diameter of 3.1mm, and screws must have a minimum diameter of 6 mm.

Due to the significantly higher load bearing capacity of the fasteners used for BauBuche when compared to fasteners in softwood, the number of fasteners per connection may be greatly reduced and shorter fasteners can be used.

For the most efficient utilisation of material, insert the fasteners into the wide sides and provide for adequate shear joints. Under certain circumstances, cross-ply might significantly affect the load bearing capacity of BauBuche, so that shorter minimum distances must be chosen and the number of fasteners must be increased.

When installing large number of fasteners, it might be useful to use collated screw systems, for instance from Adunox www.adunox.com.

5.2.2 Nails

Given the high density of the material ($\rho_k > 500 \text{ kg/m}^3$), the holes for nails in BauBuche must be pre-drilled, as specified in EN 1995-1-1. The nail hole diameter should be $0.8 \cdot$ the nail diameter. Usually, round nails with smooth or profiled shafts (special or anchoring nails) can be used, unless the fastener approval stipulates other requirements. Ring nails (ETA 13/0523: GH Baubeschläge GmbH – Ring nails 4.0 mm) are for instance approved for the use in steel platetimber connections without pre-drilling in BauBuche, provided that the maximum embedding depth in BauBuche is 34 mm. For more information, see chapter 5.2.8 and www.holzverbinder.de.

For the fixture of formed steel sheet parts or for panelling without pre-drilling, approved 5 mm joist hanger screws are a suitable alternative; see also chapter 5.2.8.

5.2.3 Clamps

The applicable standards for load bearing timber constructions prescribe that holes for pin-shaped fasteners in high-density timber ($\rho_k > 500 \text{ kg/m}^3$) must be pre-drilled. There are no approvals yet that allow for the use of clamps in BauBuche without pre-drilling.

Recent timber construction studies examining the use of clamps in BauBuche have already come to promising conclusions, and show that the installation of clamps is possible, provided they are not too narrow. However, and in particular with reference to EN 1995-1-1, the use of clamps is not yet permitted.

For the fixture of panelling without pre-drilling, approved 5 mm partial thread screws (Würth, HECO, Fischer, etc.) are a suitable alternative.

5.2.4 Screws

For screw dimensions for the use in BauBuche, consider the approvals of the screw manufacturers. These approvals normally contain upper limits for the characteristic density of the material (maximum values) that must be taken into account in the calculations.

We strongly recommend to use only screws approved for BauBuche/hardwood:

- _ ETA 12/0197: SWG Timtec – Full thread and partial thread screws
- _ ETA 12/0373: Schmid Schrauben RAPID – Full thread and hardwood screws
- _ ETA 11/0027: fischerwerke Power-Fast – Full thread and partial thread screws
- _ ETA 11/0190: Würth ASSY – Full thread and partial thread screws
- _ ETA 11/0030: Rothoblaas – Full thread and partial thread screws
- _ ETA 12/0062: SFS intec WR – Full thread screws
- _ ETA 12/0063: SFS intec WT – Double thread screws
- _ ETA 19/0175: fischerwerke Power-Fast II – 6 mm partial thread screws
- _ ETA 19/0553: HECO – Partial thread screws
- _ ETA 20/0558: SIHGA GoFix SH – Partial thread screws

If you have any information regarding other screws explicitly approved for use in BauBuche, please let us know by writing to: baubuche@pollmeier.com.

All holes for screws in BauBuche must be pre-drilled, even if screws with a drill bit are used.

As recommended for all hardwood products, BauBuche must be pre-drilled with a drill larger than the core diameter of the screw. Exact details can be found in the screw approvals.

For instructions on the insertion of the screws, refer to the pages below or the instructions of the screw manufacturer. For high screw-in torques, use set torque bits or other mounting aids such as set torque bits from Metabo or Mafell and mounting aids from SIHGA, Rothoblaas or HECO.

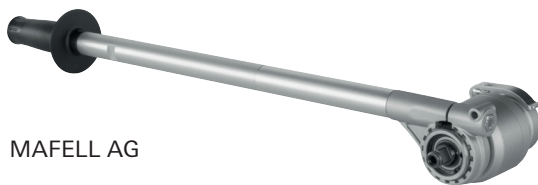

MAFELL AG



SIHGA GmbH

For pre-drilling, the specifications for beech or oak timber generally also apply to BauBuche. Extensive tests showed that pre-drilled hole diameters up to approx. $0.8 \cdot D$ (see last column in the table) have no significant effect on the axial load strength of conventional timber screw threads in BauBuche. Stiffness is reduced by maximum 22 %, and must be taken into consideration, if it affects the load bearing capacity of the construction. According to ETA 12/0197 for SWG screws, such larger pre-drilled hole diameters are also permitted by law.

Excerpt from ETA 11/0190, Würth screws:

Diameters of the holes to be pre-drilled in softwood, beech or oak

Excerpt from
ETA 12/0197,
SWG screws

Outer thread diameter [mm]	Diameters of the holes to be pre-drilled with a tolerance of ± 0.1 mm		Max. hole diameter [mm] BauBuche
	Structural timber component made of softwood	Structural timber component made of beech or oak	
4.0	2.5	3.0	3.0
4.5	2.5	3.5	3.5
5.0	3.0	3.5	4.0
6.0	4.0	4.0	4.5
7.0	4.0	5.0	5.5
8.0	5.0	6.0	6.5
10.0	6.0	7.0	8.0
12.0	7.0	8.0	9.0
14.0	8.0	9.0	11.0

Screws without pre-drilling

According to the respective approvals, the following partial thread screws can be used in BauBuche without pre-drilling. A torque limiter might be useful to prevent torsion failure of the screw.

_ ETA-11/0190 Würth ASSY, ETA 12/0197 SWG Timtec 3.0, ETA 19/0175 fischerwerke Power-Fast II and ETA 19/0553 HECO-TOPIX-plus – Partial thread screws made from carbon steel with a diameter D of 5 to 10 mm and a thread length of $L_{ef} \leq 10 \cdot D$ embedded in BauBuche

_ Screws with a diameter of up to 6 mm can be inserted well without pre-drilling, provided that there is no torsion failure. Even if the insertion of long, narrow screws (e.g. 6x300 mm) without pre-drilling in BauBuche is permitted by the relevant building regulations, we advise against it.

_ Screws with a larger diameter can be inserted without pre-drilling using a powerful machine.

The use of impact screw drivers is not recommendable, and torsion failure (e.g. caused by forced sinking of the head) must be avoided. This can be prevented by pre-sinking in the screw head area prior to installing the screw. Pre-drilling makes it significantly easier to insert the screws, and is indispensable for diameters $D > 8$ mm in most applications.

_ ETA 12/0063: **SFS intec WT** – Doppelgewindeschraube erlaubt kleine Einbindelangen in BauBuche ohne Vorbohren und bietet eine tabellarische Darstellung der Kombination mit Nadelholz.

Folgende Schrauben sind explizit für den Einsatz in Laubholz auch ohne ein Vorbohren entwickelt worden und sind sehr leistungsfähig:

_ ETA 12/0373: **Schmid Schrauben RAPID – Hardwood screw** (partial thread screw) with $D = 8$ mm

_ To insert these screws, a high-torque machine is required. For more information, see page 10.

_ ETA 11/0030: Rothoblaas HBS Hardwood partial thread screws with $D = 6$ mm and 8 mm, and **Rothoblaas VGZ HARDWOOD full thread screws** with $D = 6$ mm and 8 mm

_ According to the current ETA, full thread screws require pre-drilling to a depth of between 27 and 47% of the total screw length, as they can otherwise not be properly installed in BauBuche.

Partial thread screws can be inserted without pre-drilling.

_ ETA 20/0558: **SIHGA GoFix SH – Partial thread screws** with $D = 8$ mm

The following considerations suggest that pre-drilling should be adopted for all screw connections:

_ Pre-drilling reduces the stress on the human body and the material during insertion of the screw.

_ The distances between the fasteners can be kept small.

_ The risk of splitting is reduced.

_ Under certain circumstances, a higher embedding strength might be assumed.

Full thread screws

The use of full thread screws for timber constructions has become increasingly popular. Full thread screws are often used in common constructions as connectors that are stressed on shear because they are easy to install. However, their main advantage is their axial strength as regards tension and compression. These properties come primarily to the fore in angled screw connections with large thread lengths in both components that shall be joined. The load bearing capacity is only limited by the potential tensile failure of the screw. Full thread screws are an economical solution for transverse tensile reinforcement and for auxiliary beam connections. Further to this, the concealed installation provides advantages as regards aesthetics and fire safety. The screw connection must be fully pre-drilled in both components (exceptions see page 6). Many screw manufacturers offer handy aids for fast installation and optimised screwing angles.

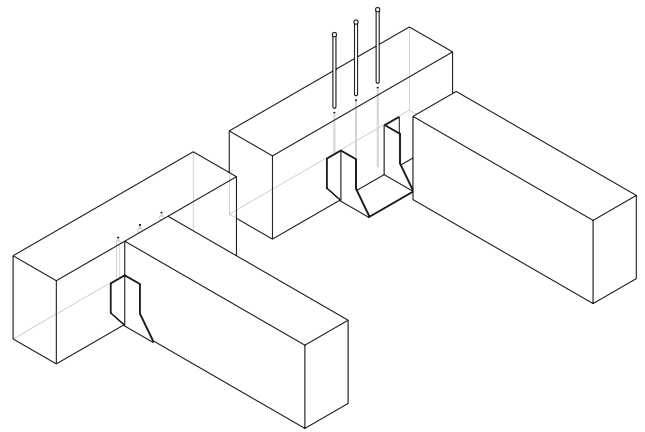

Transverse tensile reinforcement

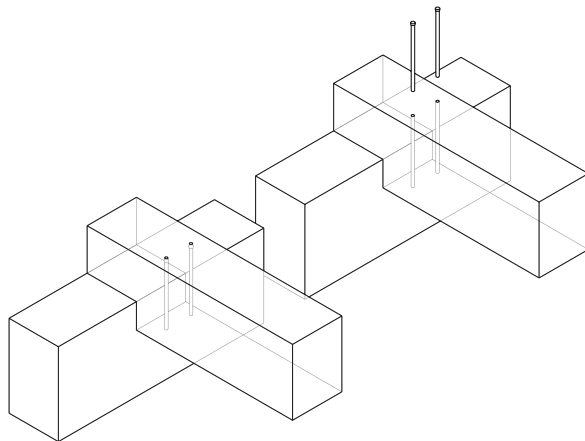

Transverse tensile reinforcement
in connection with notches

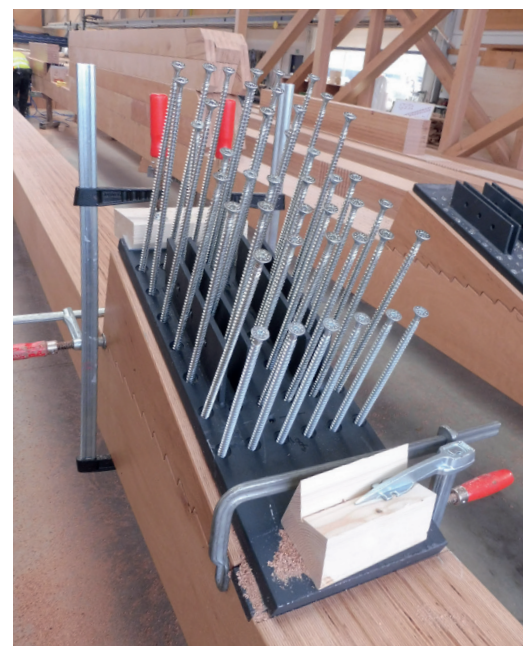

SWG production hall –
Lattice girders
sonnection with 12 mm
full thread screws

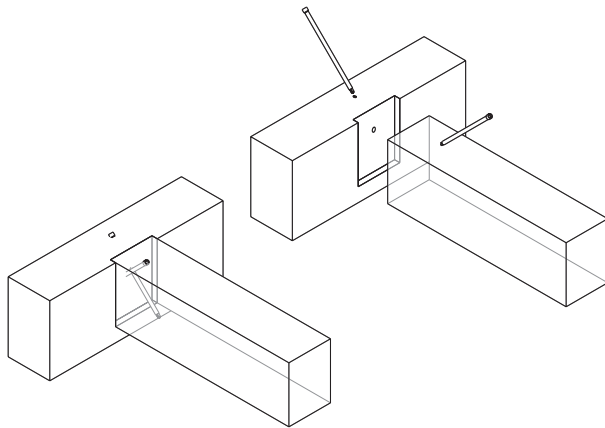

Connection between girder and auxiliary beam

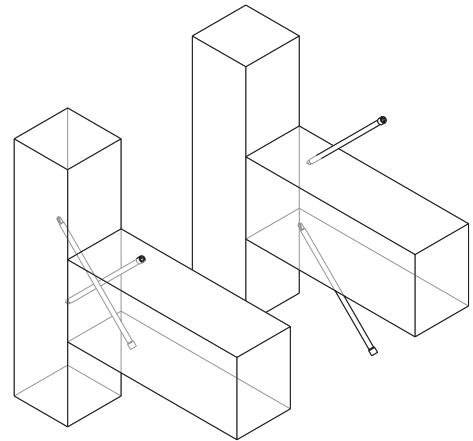

Connection between post and beam



Project euregon AG, Holzbau Gump & Maier GmbH, Installation of auxiliary beams The beams are connected with full thread screws (Würth Assy plus VG 8 · 330). In this project, pockets were milled into the girders and the ends of the auxiliary beams were machined accordingly. This approach provides for an easy installation as the auxiliary beams can be put into notches leading to a visually flawless appearance of the connection with concealed fasteners.

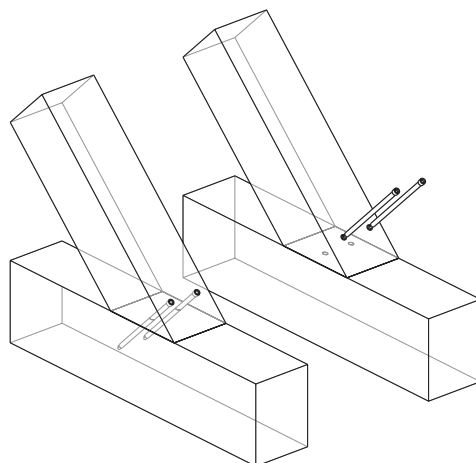

Strut connection

Simple and cost-effective solution: The screws are inserted at an angle to the girder axis so that they are exposed primarily to an axial load.

For the use of full thread screws in BauBuche, the following recommendations need to be considered:

- _ Short drill holes can be produced with a 013C drill from FISCH-TOOLS, a HSS drill from FAMAG or a multi-purpose drill from Kanne. In order to prevent excess heat, pay attention to an adequate removal of the drill chips. Drill holes that are at an incorrect angle, as often happens with auger bits, make it more difficult to insert the fasteners and can lead to a premature failure of the drill bit and/or the screw. We therefore advise against the use of auger bits.



- _ The use of drilling systems with compressed air is recommended as the air flow facilitates chip removal and also cools the drill bit which leads to very good results. Shorter drill times, a longer service life and reduced drilling run-out, especially in long bores, compensate for the higher initial investment. The deep hole drilling system from ZÜBLIN Timber Aichach GmbH for drill bits with a diameter of 3.5 to 12 mm and a length of up to 1000 mm. is recommendable.

- _ For large anchoring lengths in BauBuche (from approx. $30 \cdot D$), the insertion of full thread screws might still pose some difficulty, even if the holes are pre-drilled. Consider the following points:
 - _ Prevent a drilling run-out.
 - _ Use powerful machines or a torque converter. (torque bit)
 - _ Do not use screws with countersunk heads, as countersinking the screw head requires a much higher screw-in torque. If required, produce a counter sunk drilling for the screw head.
 - _ In order to countersink cheese-head screws, you need extra powerful machines.
 - _ When inserting the screw, avoid torsion failure.
 - If required, use a torque limiter.
 - _ Insert the screws in a single work step, as this limits the risk of torsion failure.
 - _ Do not use impact screw drivers.
 - _ Consider modifying the construction of the connection in order to reduce the anchoring length and thus the insertion resistance, e.g. by pre-drilling with a larger diameter in the tip section of the screw for transverse tensile reinforcement, see also next page.
 - _ Larger permissible pre-drill diameters (e.g. according to ETA-12/0197 for SWG screws, see page 5) reduce the torsional resistance for driving in the screws.
 - _ Mounting aids (e.g. from SIHGA, Rothoblaas or HECO) facilitate installation, as there is no longer a need to apply pressure on the bit during the entire driving-in process.
 - _ Rothoblaas VGZ HARDWOOD full thread screws with $D = 6\text{ mm}$ and 8 mm require only short pre-drilled depths of between 27 and 47% of the total screw length, so that there is no need for deep holes for the full thread screws.

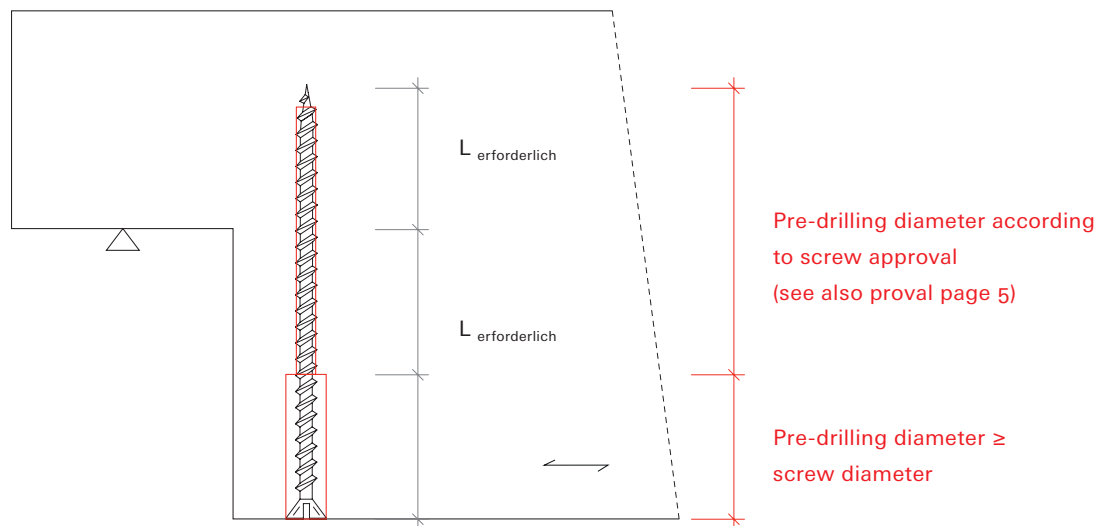

Partial thread screws

Partial thread screws are a viable alternative to full thread screws for many connections. Provided that the specified approved dimensions for BauBuche (e.g. ETA 12/0197) are considered, the full achievement potential of BauBuche components can be utilised. It is thus possible to dimension connections using partial thread screws (thread length approx. $10 \cdot D$) with washer heads in such a way that the decisive design load is within the range of the steel load bearing capacity of the screws.

The chart below shall illustrate this topic, however, it does not replace structural calculations.

$F_{tens,Rd}$ Design value of steel tensile capacity of screws

$F_{head,Rd}$ Design value of axial pull-through capacity

$F_{ax,Rd}$ Design value of axial load capacity (timber failure)

Many screw suppliers provide calculation and design tools in the form of software or strength tables for their products.

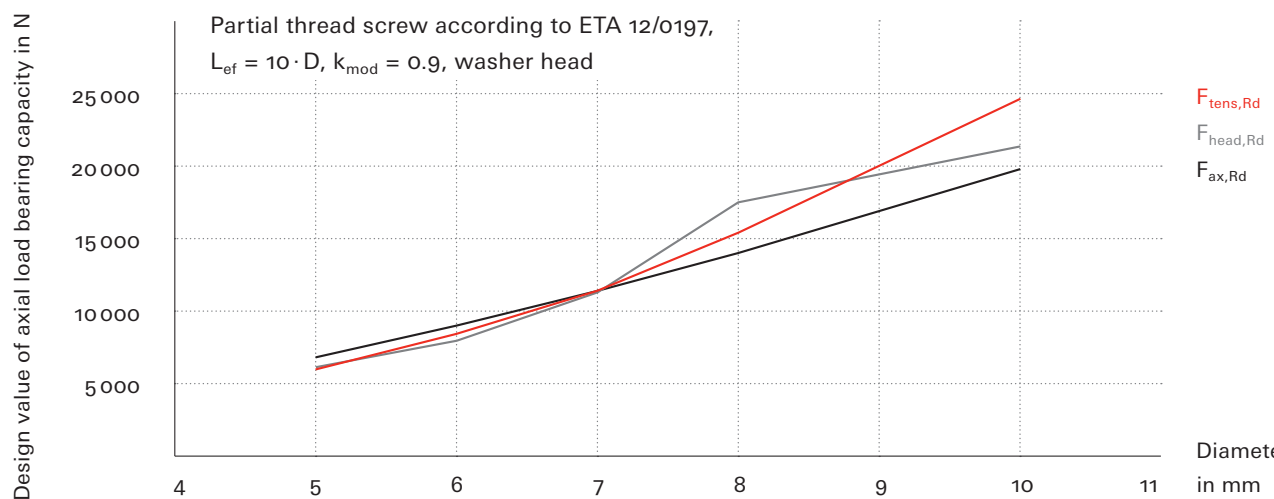
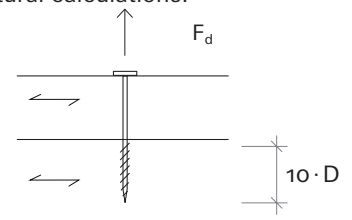

The hardwood screw from Schmid Schrauben Hainfeld (ETA 12/0373) that can be inserted into BauBuche without pre-drilling reaches the axial steel load bearing capacity of an 8 mm screw from a thread length of at least 100 mm. It therefore offers high characteristic load bearing capacities of up to $F_{ax,Rk} = 32.8$ kN in screw axis direction. Due to the high embedding strength and yield moment, high calculated values can be put on also under shear stress. Further information and dimensioning tables are provided by the manufacturer: e.g. www.schrauben.at/schraubenwelten/rapid/rapid-hardwood

Similar information on the Rothoblaas HBS hardwood partial thread screws diameters 6 mm and 8 mm is available at: [Link](#)

The recommendations on pages 5 and 9 also apply to partial thread screws and should therefore be observed. To increase the pull-through capacity, consider using standard washers or special angled washer designed specifically for 45° applications in BauBuche, see [Würth ETA-11/0190](#) or [Knapp ETA-19/0628](#).

5.2.5 Dowels/fitting bolts/bolts

Connections with dowels and slotted plates

In timber constructions, multi-slit steel-timber connections with joist brackets and through dowels have proven most successful. The steel parts are thereby completely recessed into the timber. Apart from the aesthetic aspects, such connections offer also greater safety in the event of a fire, as exposed steel parts quickly lose their strength when becoming hot. As all parts must be machined and assembled with extreme accuracy, such constructions are only possible with the help of CNC machining.

For BauBuche the pre-drill diameter must be slightly larger than for other lumber materials (e.g. $D + 0.1\text{ mm}$), in order to facilitate the insertion of the screws.

Pre-drill diameters that are smaller than the dowel diameters commonly used in hardwood, are not recommended.

For more information on CNC machining of BauBuche, refer to the CNC machining manual.

For proper drainage preventing water logging near the fasteners, provide draining bores or make sure that the slots are open at both sides.

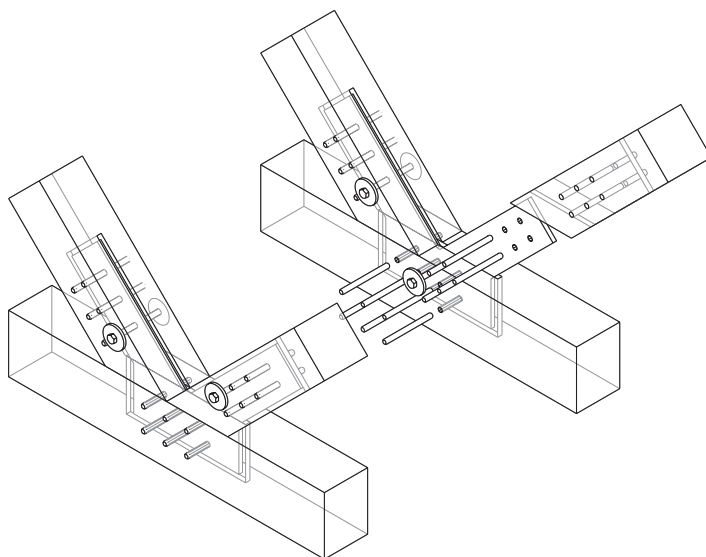

Detailed view of connection using dowels and slotted plates

Project Zukunftspavillon Frankfurt

Timber construction Hess Timber GmbH

Photos Rensteph Thompson, Chris Kister

Post base with connection
of dowel and slotted plate

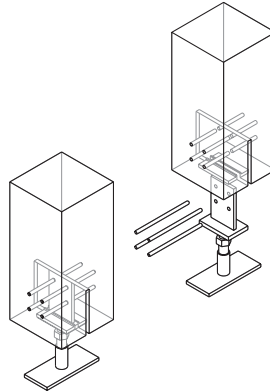

Connection for wall bonds
with connections of dowels
and slotted plates

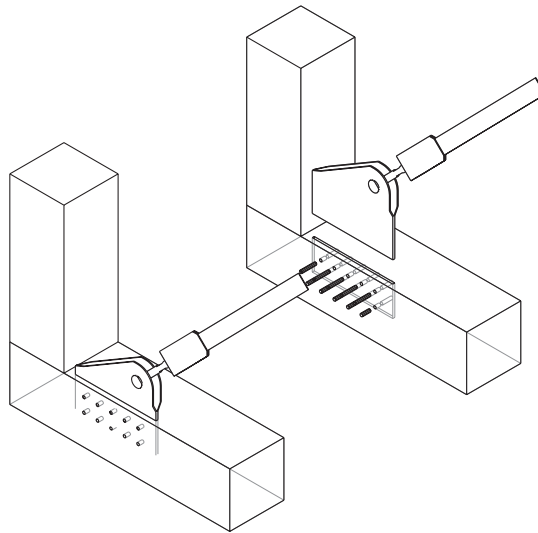

The connections of steel plates and timber are dimensioned according to the applicable timber construction standard (Eurocode 5, chapter 8). Rod dowels, bolts, fitting bolts and other suitable approved elements can be considered as dowel type fasteners. As a rule, fasteners installed in wide sides have a higher calculated load capacity and that their number can thus be reduced. Dimensioning examples and further information can be found in the **dimensioning tables**.

5.2.6 Rail splice connectors

Rail splice connectors are approved two-part system fasteners. The metallic connecting elements are fixed with full thread screws or other screw types to the timber elements. The connecting elements can either be screwed flat to the surface or they can be countersunk into milled notches. The second option allows for connections with concealed fasteners and offers advantages as regards fire safety. The connecting elements are tied positively, similar to dovetailed joints, and the connection can also be additionally secured with screws. This system is not only suitable for timber-to-timber connections but also for connections between timber and steel or concrete components. Always consider the approvals of the fastener manufacturers. BauBuche needs to be pre-drilled for all dowel type fasteners, unless explicitly allowed without pre-drilling in the fastener approval.

Examples of rail splice connectors explicitly approved for BauBuche/hardwood:

- _ ETA 11/0036: GH Baubeschläge TOP UV Connector
- _ ETA 15/0667: Knapp Megant
- _ ETA 10/0189: Knapp Ricon und Ricon S
- _ ETA 12/0067: Sherpa connector

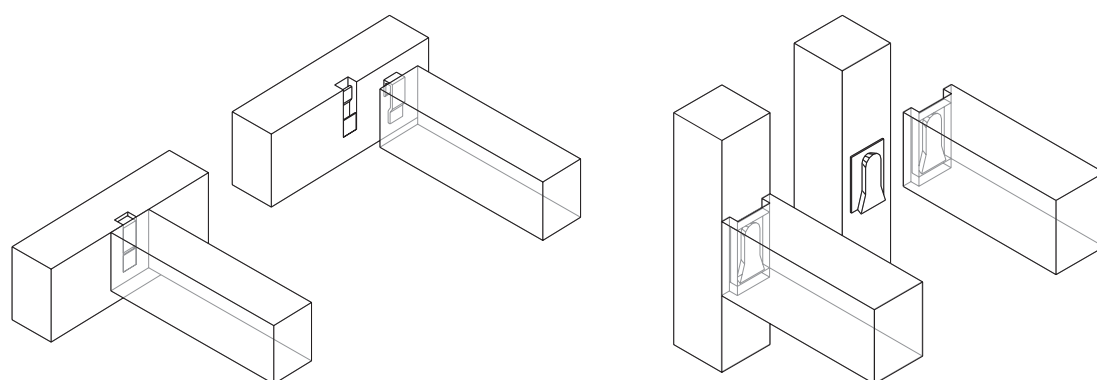

The characteristic load bearing capacities in insertion direction of the Sherpa XXL connectors are listed in the following table:

Characteristic load bearing capacity $R_{2,k}$ in kN

SHERPA connector	SHERPA screw	Schmid hardwood screw
Screw diameter in mm	8.0	8.0
Screw length in mm	120	120
XXL 100	154.5	167.9
XXL 120	200.2	217.6
XXL 140	244.7	266.0
XXL 170	288.3	313.4
XXL 190	331.2	360.0
XXL 220	373.5	406.0
XXL 250	415.3	451.4
XXL 280	456.5	496.2
XXL 300	540.8	540.8

General notes regarding the use of SHERPA connectors:

- _ Diagonally inserted screws can be installed without pre-drilling, whereby we still recommend drilling positioning points to facilitate the installation of fasteners
- _ Pre-drilling is necessary for »torque screws« inserted at right angles to the connector plane.
- _ SHERPA connectors combined with in BauBuche can be dimensioned using the »SHERPA-Verbinder« module of the ingtools design software.
- _ Observe the valid approval (ETA-12/0067 of 17/09/2019) of the manufacturer.

5.2.7 Beam connectors

The one-piece connectors are suitable for load-bearing, non-visible timber-to-timber connections, for instance between auxiliary beams and girders or beams and posts. Beam connectors are screwed to one of the timber components and attached to the second component by means of a dowel-slotted connection with dowels and slotted plates. Visible connections can also be produced at different angles. A groove at the front end of the beam connector together with a pre-installed dowel of the auxiliary beam provides for an easy installation. Observe the approvals of the fastener manufacturers. With BauBuche, the holes for all pin-shaped fasteners must be pre-drilled, unless specified otherwise in the fastener approval.

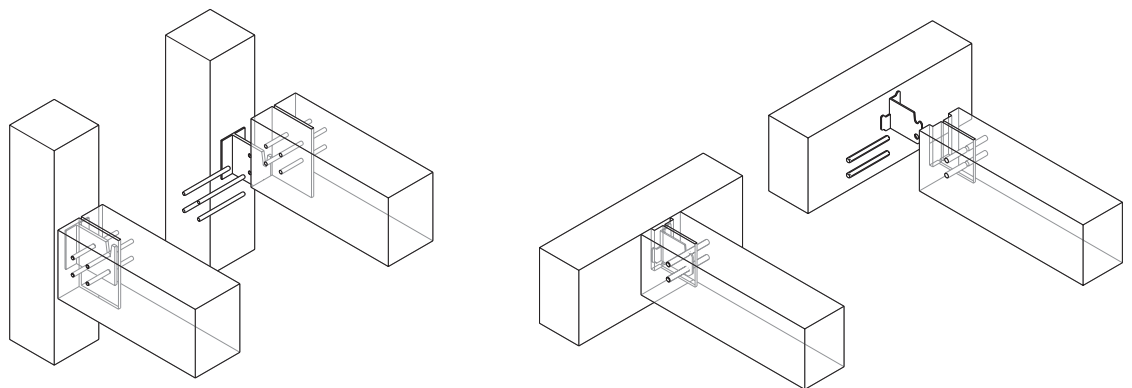

5.2.8 Preformed steel parts

Preformed steel parts are metal components for fastening timber components to timber, steel or concrete elements. In most cases, the timber element is secured to the steel part by means of ring nails, but screws are equally suitable. As a rule, the holes for screws and nails have to be pre-drilled when using BauBuche, unless specified otherwise in the respective fastener approvals (see also chapters 5.2.2 and 5.2.4).

The approvals and information of the fastener manufacturers have to be considered.

Preformed steel parts are primarily used in non-visible areas.

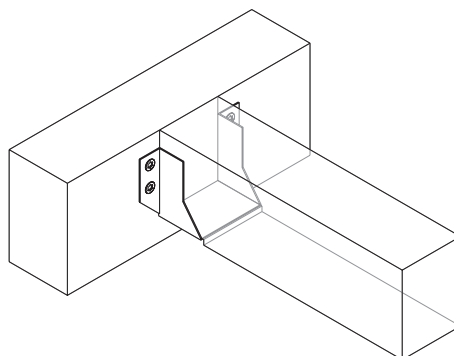

At the moment, for example, the following fasteners for the attachment of preformed steel parts (joist hangers, perforated strap ties, tie rods, etc. are approved for use without pre-drilling:

_ ETA 12/0197: SWG Timtec 3.0 or ETA 11/0190: Würth ASSY 4.0 – Joint hanger screws such as Timtec 3.0 or ASSY 4.0 with diameter 5 mm and length 35 mm (thread length 30 mm)

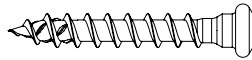

$$F_{ax,Rk} = 5.25 \text{ kN}$$

$$F_{v,Rk} = \begin{cases} 3.0 \text{ kN by } t < 1.5 \text{ mm} \\ 3.7 \text{ kN by } t \geq 1.5 \text{ mm} \end{cases} \text{ (screw inserted into wide side; load in grain direction)}$$

$$F_{v,Rk} = \begin{cases} 3.1 \text{ kN by } t < 1.5 \text{ mm} \\ 4.0 \text{ kN by } t \geq 1.5 \text{ mm} \end{cases} \text{ (screw inserted into wide side; load perpendicular to grain direction)}$$

ETA 13/0523: GH connector nails – Ring nails 4.0 · 35 mm

We recommend testing in advance whether the nails can be driven in without pre-drilling.



$$F_{ax,Rk} = 2.5 \text{ kN}$$

$$F_{v,Rk} = 3.5 \text{ kN (thin steel plate and screw inserted into wide side; load in grain direction)}$$

$$F_{v,Rk} = 4.4 \text{ kN (thin steel plate and screw inserted into wide side; load perpendicular to grain direction)}$$

5.2.9 Installation on site / load-securing devices

To transport the BauBuche elements, use systems approved for this task, for instance **transport anchoring screws** in combination with **transport anchors** or special systems such as **pick connectors**.

5.2.10 Fixture of large-size roof and wall elements

There are already expert reports examining screws, including screws not requiring pre-drilling, for the fixture of trapezoidal sheet metal or sandwich elements. However, at the time of going to print, the respective approval procedures for suitable screws have not yet been completed. If you are planning a project with such elements, please write us at baubuche@pollmeier.com for more information.

5.3 Carpentry connections

5.3.1 Introduction

Since the introduction of CNC machines that allow for precision-manufacturing of components, carpentry connections are a viable alternative to mechanical connections in present-day timber construction. The high transverse compression and shear strength of BauBuche have benefits for efficient contact joints.

5.3.2 Step joints

For butt joints such as struts, step joints are the most commonly used connection. Given the high transverse compression and shear strength of BauBuche, step joints are an extremely efficient option. The basic requirement for a proper load transmission with little deformation is an accurate machining. Step joints have to be secured with bolts or screws.

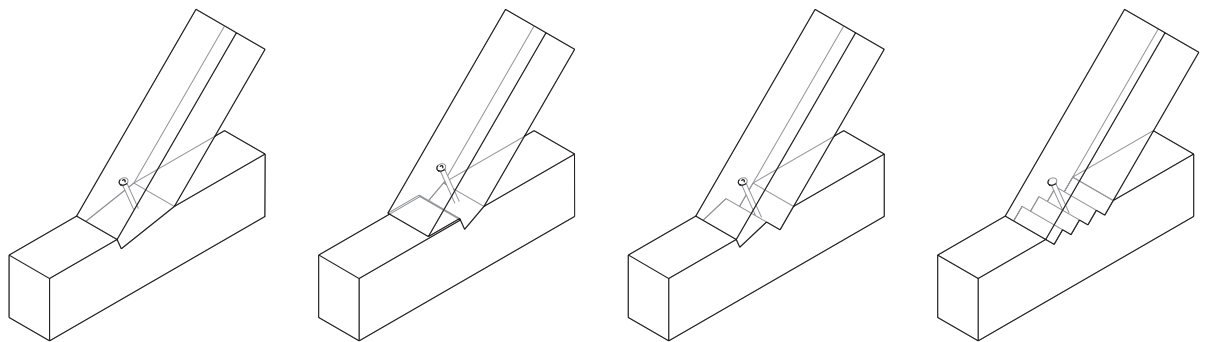

Single step joint

Heel notch joint

Double step joint

Multiple step joint



BauBuche GL75, strut connection with single step joint

Project Tischlerei Mohr Timber construction Kaufmann Zimmerei

Single step, double step and heel notch joints for BauBuche can be dimensioned using Module »Versätze« (step joints) of the dimensioning software available from www.ing-tools.de.

The special properties of BauBuche allow for further development of traditional connections that are more efficient. The multiple step joint is such an optimised contact connection providing a particularly high performance. There is no normative standard for such joints yet, however, they can be dimensioned using a shear and transverse loadcarrying analysis.

For dimensioning advice see:

- _ Enders-Comberg, M., Blaß, H.J.; Treppenversatz – Leistungsfähiger Kontaktanschluss für Druckstäbe; Bauingenieur, Volume 89, 04/2014, Springer-VDI-Verlag, Düsseldorf

The following section takes a closer look at the multiple step joint with regard to the above-mentioned publication and described dimensioning.

Analysis of transverse compressive strength $R_{c,90,k}$

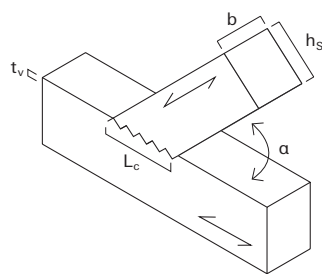

Resistance in longitudinal strut direction $R_{c,90,k} = \frac{A_c \cdot f_{c,90,k}}{\sin \alpha}$

Length of pressure-loaded area $L_c = \frac{h_s}{\sin \alpha}$

Pressure-loaded $A_c = b \cdot (L_c + 2 \cdot 30 \text{ mm})$

Analysis of shear strength $R_{v,k}$

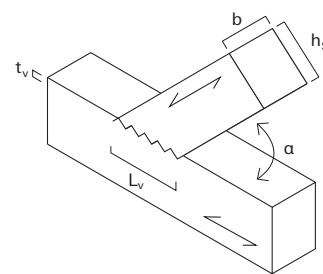

Resistance in strut direction $R_{v,k} = \frac{A_v \cdot f_{v,k}}{\cos \alpha}$

Length of shear surface $L_v = \frac{h_s}{\sin \alpha}$

Shear surface $A_v = b \cdot L_v$

The relevant load bearing capacity in strut direction can be calculated as follows:

$$R_d = k_{mod} / \gamma_M \cdot \min\{R_{c,90,k}; R_{v,k}\}$$

Vertically standing parts in the chord can increase the load bearing capacity by up to 100%, because, if applicable, a higher shear and transverse compressive strength can be assumed. The alignment of the parts within the strut has no effect on the load bearing capacity and stiffness of the connection.

The load bearing capacity of the multiple step joint in BauBuche can be determined with the help of the diagram below: Rated value of load bearing capacity in longitudinal strut direction:

$$R_d = k_{mod} / \gamma_M \cdot R_k^{(diagram)} \cdot w / 100 \text{ mm (width } w \text{ in mm)}$$

The load bearing capacity of the multiple step joint is not dependent on the incision depth t_v . However, it should be minimum 10 mm.

Decisive load bearing capacity of multiple step joint per 100 mm width

Horizontal laminations in chord element

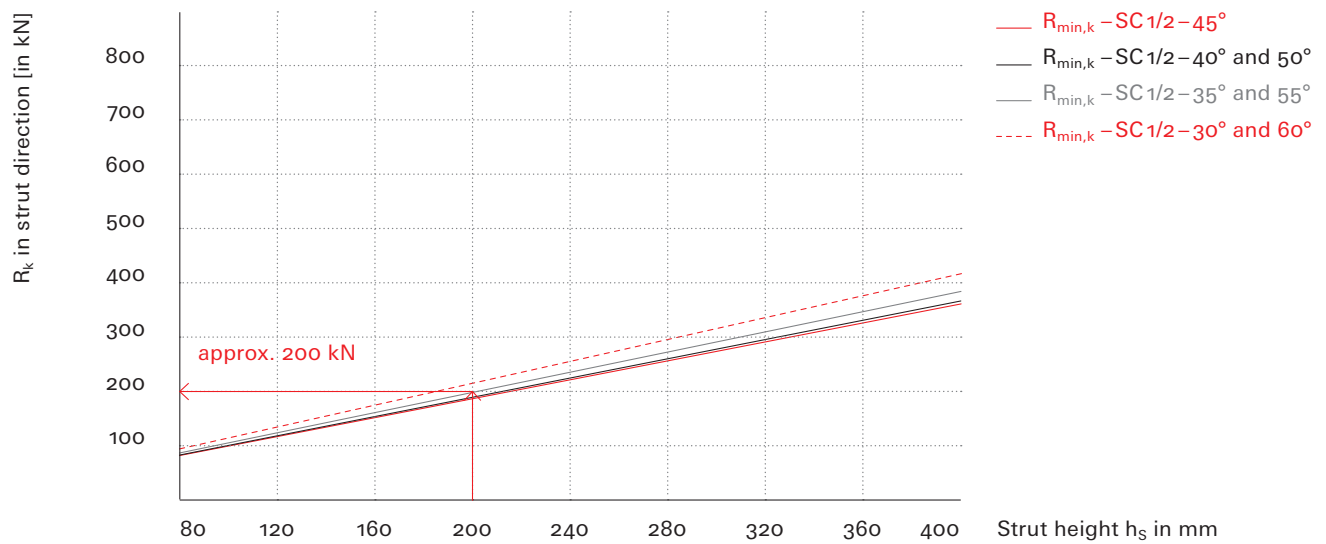

Load bearing capacity of multiple step joint per 100 mm width

Vertical laminations in chord element

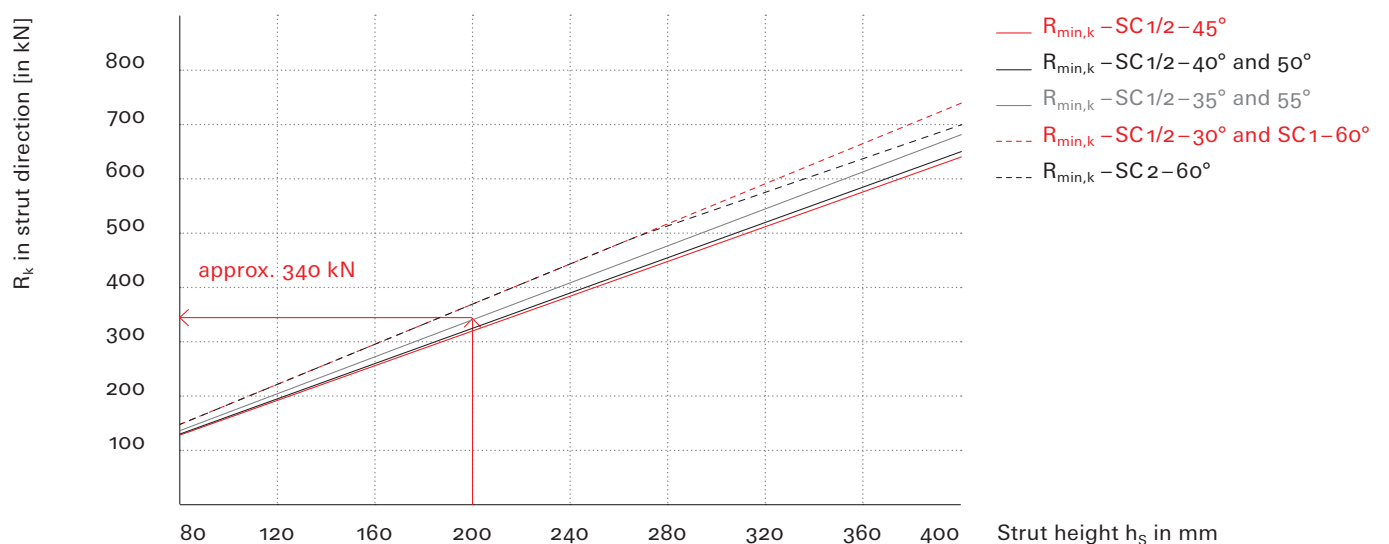

In order to illustrate the performance of BauBuche and especially of the multiple step joint, the optimisation potential is shown below, based on a single step joint in GL 24h:

Example: Strut 200 · 200 mm with $\alpha = 55^\circ$, service class 1

- a) Single step joint in GL 24h with incision depth of 25 mm: $R_k = 82 \text{ kN}$
- b) Single step joint in Beam BauBuche GL75 with incision depth of 25 mm: $R_k = 118 \text{ kN}$
- c) Multiple step joint in BauBuche Beam GL75 with incision depth of 10 mm and horizontally placed parts in the: $R_k = 400 \text{ kN}$
(See above diagram: $R_k = R_k^{(\text{diagram})} \cdot w / 100 \text{ mm}$
 $= 200 \cdot 200 \text{ mm} / 100 \text{ mm}$
 $= 400 \text{ kN}$)
- c) Multiple step joint in BauBuche Beam GL75 with incision depth of 10 mm and vertically placed boards in the chord: $R_k = 680 \text{ kN}$
(See diagram above: $R_k = R_k^{(\text{diagram})} \cdot w / 100 \text{ mm}$
 $= 340 \cdot 200 \text{ mm} / 100 \text{ mm}$
 $= 680 \text{ kN}$)
-

Due to the excellent performance of BauBuche in combination with multiple step joints, the stability verification of the compression strut is usually the decisive factor.

5.3.3 Dovetailed joints

Due to the growing use of modern CNC machines, dovetailed joints can nowadays be produced efficiently. Together with their appealing look this leads to an increasing popularity of this connection. Dovetailed joints for load bearing constructions require a technical approval.

Verband High-Tech-Abbund im Zimmererhandwerk e.V. (www.lohn-abbund.de) is the holder of the General Technical Approval DIBt Z-9.1-649 for dovetailed joints. Since June 2018, the approval also covers BauBuche, and the document is available to all members of the association.

According to the above approval, dovetailed joints must only be used in cases where the load occurs in insertion direction or at right angles to the insertion direction. Dovetailed joints made of BauBuche reach an approx. three times higher load bearing capacity and stiffness compared to solid timber or softwood glulam of the same component dimensions.

According to the approval, the following strength values can be used to calculate the load bearing capacity of a dovetailed joint in BauBuche: $f_{t,90,k} = 1.5 \text{ N/mm}^2$; $f_{v,k} = 8.0 \text{ N/mm}^2$. For more detailed information see DIBt Approval Z-9.1-649 (dated 06/2018).

Dovetailed joints with BauBuche can be dimensioned using module »Schwalbenschwanz« of the dimensioning software at www.ing-tools.de.

Due to the distinct shrinking and swelling behaviour of BauBuche, the expected equilibrium moisture content has to be taken into account for the CNC manufacturing. It might therefore be necessary to slightly enlarge the mortise in order to facilitate assembly.

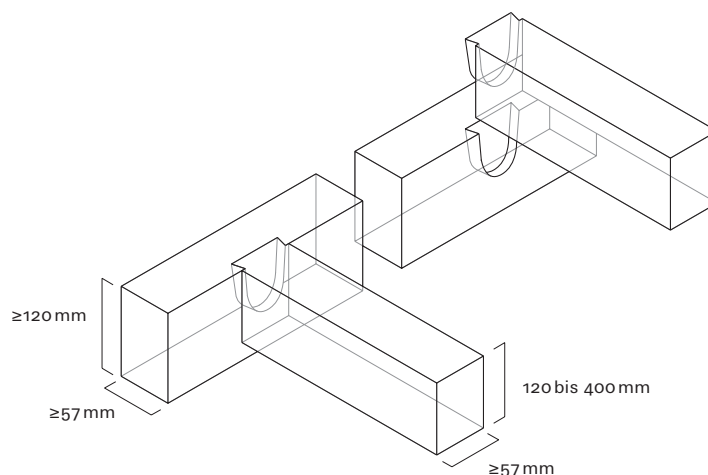

5.4 Glued connections

5.4.1 Introduction

For glued connections, the national annex of Eurocode 5 refers to DIN 1052-10 or a general technical verification of applicability for glued connections, which means that there are restrictions regarding the use of such connections. Glued construction products either require

- _ a harmonised standard (e.g. EN 14080 for glued laminated timber made of solid softwood)
- _ an ETA (e.g. for glulam made of beech LVL)
- _ a general technical approval (e.g. Z-9.1-838)
- _ or a bonding as described in DIN 1052-10.

All other load bearing glued timber elements (e.g. finger joint connection) or new construction products made by bonding other construction products require individual approvals. For load bearing glued timber elements as per general technical approval and/or DIN 1052-10 a proof of suitability (»official gluing authorisation«) is required. For the granting of a proof of suitability, a material test is performed in-house, the in-process production control at the factory is evaluated and the need for staff training (e.g. by means of a gluing technique course) is examined. In addition, exemplarily manufactured samples with reinforced glued joints are tested.

For more information, contact a nationally approved or notified European supervisory or certification body, e.g. https://www.mpa.uni-stuttgart.de/organisation_new/bereich_bauwesen/holzkonstruktionen

The general technical approval Z-9.1-838 for BauBuche Board states the following as regards other glued joints:

According to DIN 1052-10, laminated veneer lumber may be glued to other construction materials in the following cases, provided that the respective gluing instructions and specifications are adhered to:

- _ Laminated veneer lumber with cross-ply for the use as covering for glued timber panel elements
- _ Laminated veneer lumber without cross-ply for the use as ribs in glued timber panel elements
- _ In Germany as per DIN 1052-10 where the standard does not include specific requirements with regard to proof of usability (e.g. affixed reinforcements)

Structural joints without load transmission through the glue joint are possible in general. Further glued connections with other construction materials or laminated veneer lumber parts with each other might be controlled by other general technical approvals.

5.4.2 Glued timber panel elements

The production of glued timber panel elements is regulated in DIN 1052-10, chapter 6.7. Provided that the specifications as stated there and the framework requirements as per the approval Z-9.1-838 for BauBuche Boards are met, such elements can be produced and used. The company realising the glued connection requires a certificate of suitability C2, which generally includes an initial sample inspection of the glue connections of timber panel elements.

In case of huge deviations from the specifications, an individual approval is required.

5.4.3 Screw press bonding

The requirements for screw press bonding are laid down in DIN 1052-10, chapter 6.2. Provided that the specifications stated there are met (covering up to 50 mm thickness, use of a gap-filling adhesive, among other things), such connections can be produced and used. The company realising the glued connections requires a certificate of suitability B or C2 which generally includes an initial sample testing of the screw press bonds made with BauBuche. In exceptional cases, an individual approval might be required.

5.4.4 Affixed reinforcements

Affixed reinforcements are controlled by DIN 1052-10, chapter 6.3. Provided that the specifications stated there are met, such connections can be produced, also by means of screw press bonding, and used. The company realising the glued connections requires a certificate of suitability B which generally includes an initial sample testing of the bonds made with BauBuche. In exceptional cases, an individual approval might be required.

5.4.5 Glued-in steel rods

According to the approval Z-9.1-705 (2C WEVO EP32 adhesive), steel bars (reinforcing bars and threaded bolts) may be glued into BauBuche elements. Approval Z-9.1-705 and the relevant national annex of Eurocode 5 need to be considered. As there should be no significant increase in wood moisture content after gluing, we advise against the use of glued-in steel rods for service class 2.

The contractor producing the glue bonds must be in possession of gluing approval B, which generally includes an initial sample inspection of the bonds with BauBuche.